



Tiempo y
Tecnología S.A. de C.V.

Ficha técnica del producto

AMG-1700

Series

Barrera de
Estacionamiento



Amano McGann's AMG-1700 Series está diseñada para satisfacer todas las necesidades para el control de su estacionamiento. El microprocesador basado en lógica y funcionalidad, proporciona lo último en habilidad, rendimiento y seguridad así como la facilidad de acomodar cuatro diferentes modos de funcionamiento

Barrera de Estacionamiento

AMG-1700

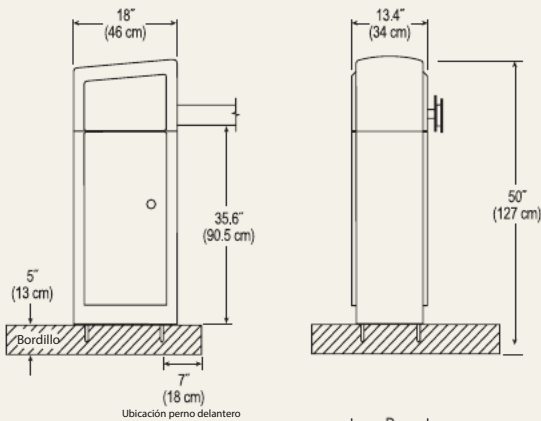

Letra	Me
A	8.7" (22 cm)
B	7" (18 cm)
C	11.8" (30 cm)
D	13.4" (34 cm)
E	18.64" (47.4 cm)
F	9.9" (25.16 cm)
G	6" (15.24 cm)

confinar conducto rígido no más de 2" de altura en este area

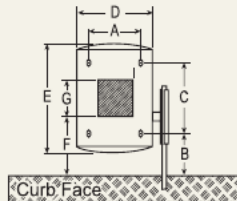

FEATURES

- ◀ Slim, cabinet-style design
- ◀ Four selectable modes of operation
- ◀ Pre-installed detector harness
- ◀ Microprocessor-based logic and functionality
- ◀ Standard "extra sensory" safety feature
- ◀ Instant reversing motor
- ◀ 1/3 horsepower motor with sealed gear reducer
- ◀ Internal thermal/overload protection
- ◀ Thermostat-controlled heater
- ◀ 12' standard gate arm, and 11' standard folding gate arm configurations available
- ◀ Dual powder coat finish

Especificaciones

Electricidad

120V AC, 60 Hz
220/240V AC, 50/60 Hz
Amp. de servicio: 20A (120V)
Conecciones: Cuatro tomacorrientes de utilidad
DIN rail terminal blocks, incluyendo la lógica
Interruptores de alimentación principal
Cableado de obra: bloque de terminales extraíble
Contactos secos de entrada y salida
12V DC no regulados

Características del Motor

Caballos de fuerza: 1/3 de una sola fase del motor de marcha atrás
Velocidad: 1625 RPM
Amperios de inicio: 10A (120V) maximum
Amperios trabajando: 4.5A (120V)
Heavy-duty V-belt to drive speed reducer
Internal thermal/overload protection

ENVIRONMENT

Temperature: -20°F ~120°F (-29°C ~ 49°C)
Automatic thermostat-controlled heater included
Humidity: 10% ~ 90% (non-condensing)

HOUSING

Heavy-duty, 14-gauge all-weather steel construction
Dimensions: 45.1"H x 13.4"W x 18.6"D (114 cm x 34 cm x 47 cm)
Weight: 166 lbs. (75 kg)
Access: Removable cover on drive mechanism (360° access)
Lockable door (access to electrical connections and control box)
Finish (Std): Argent Silver (#305) cabinet / Classic Grey (#314) side panels; White (RAL#9003); custom color available

GATE ARM

Height: 34" (86 cm) as shipped in down position
Length: AL12: 12' (365 cm) — aluminum
AL25: 11' (323 cm) folding gate arm — aluminum
Optional sonic alert: Audible alarm kit (AGP-0517/A627)

MICROPROCESSOR-BASED CONTROLLER

Quick, plug-in installation. Gate up/normal/down switch (internal manual override).
Operation modes: One way pay
Bi-directional lane
Free direction
Input/output lane controller
Switch selectable features: "Extra sensory" timer
Backout timer
Closing loop safety "auto stop"

Manufactured by Amano Cincinnati, Inc's Ohio factory, an ISO 9001:2000 registered facility. Specifications are approximate and are subject to change without notice. UL approval does not apply to 220/240V AC, 50/60 Hz



REPRESENTED BY:

AMANO McGANN®

Parking Gate
AMG-1700

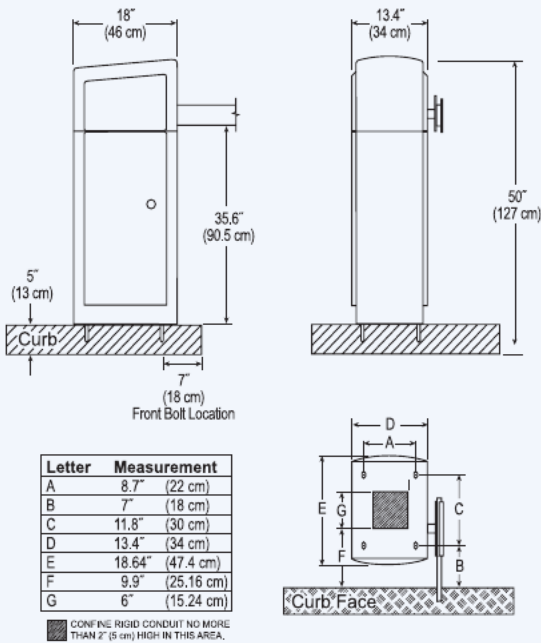

FEATURES

- ◀ Slim, cabinet-style design
- ◀ Four selectable modes of operation
- ◀ Pre-installed detector harness
- ◀ Microprocessor-based logic and functionality
- ◀ Standard "extra sensory" safety feature
- ◀ Instant reversing motor
- ◀ 1/3 horsepower motor with sealed gear reducer
- ◀ Internal thermal/overload protection
- ◀ Thermostat-controlled heater
- ◀ 12' standard gate arm, and 11' standard folding gate arm configurations available
- ◀ Dual powder coat finish

SPECIFICATIONS

ELECTRICAL

120V AC, 60 Hz
220/240V AC, 50/60 Hz
Service amps: 20A (120V)
Connections: Four utility power outlets
DIN rail terminal blocks including logic
Main power breakers
Field wiring: Removable terminal block assembly
Dry contact input, output
12V DC unregulated

MOTOR CHARACTERISTICS

Horsepower: 1/3 single-phase instantly reversing motor
Speed: 1625 RPM
Starting amps: 10A (120V) maximum
Running amps: 4.5A (120V)
Heavy-duty V-belt to drive speed reducer
Internal thermal/overload protection

ENVIRONMENT

Temperature: -20°F ~120°F (-29°C ~ 49°C)
Automatic thermostat-controlled heater included
Humidity: 10% ~ 90% (non-condensing)

HOUSING

Heavy-duty, 14-gauge all-weather steel construction
Dimensions: 45.1"H x 13.4"W x 18.6"D (114 cm x 34 cm x 47 cm)
Weight: 166 lbs. (75 kg)
Access: Removable cover on drive mechanism (360° access)
Lockable door (access to electrical connections and control box)
Finish (Std): Argento Silver (#305) cabinet / Classic Grey (#314) side panels; White (RAL#9003); custom color available

GATE ARM

Height: 34" (86 cm) as shipped in down position
Length: AL12: 12' (365 cm) — aluminum
AL25: 11' (323 cm) folding gate arm — aluminum
Optional sonic alert: Audible alarm kit (AGP-0517/A627)

MICROPROCESSOR-BASED CONTROLLER

Quick, plug-in installation. Gate up/normal/down switch (internal manual override).
Operation modes: One way pay
Bi-directional lane
Free direction
Input/output lane controller
Switch selectable features: "Extra sensory" timer
Backout timer
Closing loop safety "auto stop"

Manufactured by Amano Cincinnati, Inc.'s Ohio factory, an ISO 9001:2000 registered facility. Specifications are approximate and are subject to change without notice. UL approval does not apply to 220/240V AC, 50/60 Hz



REPRESENTED BY:

AMANO McGANN®